

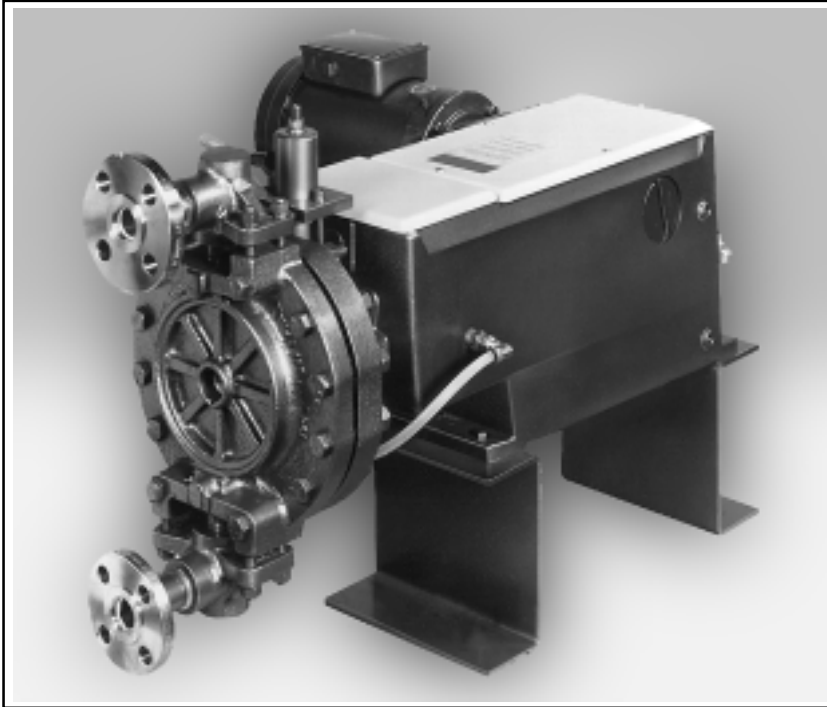

MILROYAL B PUMPS

MILROYAL B SIMPLEX WITH HPD LIQUID END (shown with optional langes)



GENERAL SPECIFICATIONS

Drive

Polar Crank Design - all moving parts submerged in oil

Liquid Ends Available

High Performance Diaphragm (HPD)
Packed Plunger
Disc Diaphragm

Multiplexing

Up to 8 pumps driven by one motor. (Limited to total of 10 HP.) Consult Applications Engineering concerning capabilities for specific application.

Maximum Performance Ratings (per head)

500 gph (1893 l/h) @ 100 psig (7 bar) to
3.4 gph (13 l/h) @ 10,000 psig (1450 bar)

Capacity Control

Manual Micrometer (std)
Electronic, Pneumatic, or Variable Speed (opt)

Accuracy

±1.0% over 10:1 turndown ratio

Weight (simplex)

Approximate shipping weight is 250-600 lbs. (113-272 kg), depending on liquid end selected.

MILROYAL B TRIPLEX

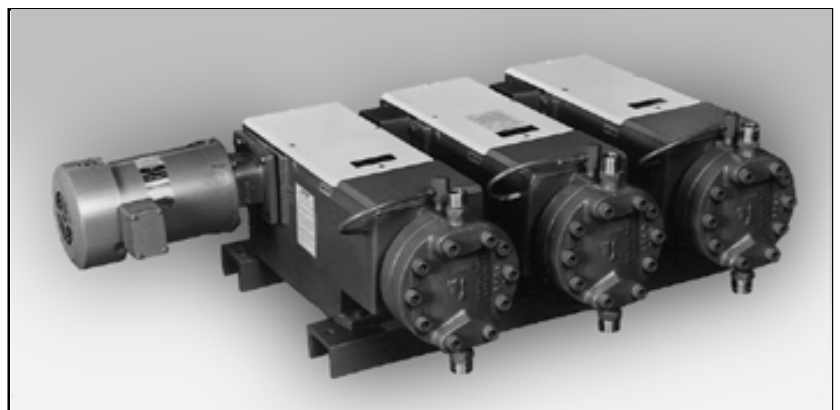



HIGH PERFORMANCE DIAPHRAGM (HPD) LIQUID END PERFORMANCE

Typical performance based on 1725 RPM, 3 phase*, 60 hz motor. Derate flow rates for all other RPM speeds.

MILROYAL B

Plunger Dia.	Gear Ratio Code	SPM @ 1725 RPM	Maximum Capacity*		1/3HP (0.25 kW)		1/2 HP (0.37 kW)		3/4 HP (0.55 kW)		1 HP (0.75 kW)		1 1/2 HP (1.1 kW)		2 HP (1.5 kW)	
					PSIG	BAR	PSIG	BAR	PSIG	BAR	PSIG	BAR	PSIG	BAR	PSIG	BAR
			GPH	L/H	Maximum Discharge Pressure*											
7/16" (11 mm)	8K	49	2.1	7	3440	237	3675	250	—	—	—	—	—	—	—	—
	8J	70	3.0	11	1625	112	3215	222	3675	250	—	—	—	—	—	—
	8H	95	4.0	15	1110	77	2440	168	3675	250	—	—	—	—	—	—
	8G	113	4.9	18	775	53	1905	131	3675	250	—	—	—	—	—	—
	8F	142	6.1	23	575	40	1475	102	2950	203	3675	250	—	—	—	—
9/16" (14 mm)	8K	49	3.8	14.4	1730	118	2780	189	3675	250	—	—	—	—	—	—
	8J	70	5.4	20.4	975	66	1830	124	2750	187	3675	250	—	—	—	—
	8H	95	7.3	27.6	650	44	1350	92	2030	138	3055	208	3675	250	—	—
	8G	113	8.7	32.9	500	34	1125	77	1700	116	2730	186	3675	250	—	—
	8F	142	11	41.6	375	26	900	61	1350	92	2400	163	3600	245	3675	250
5/8" (16 mm)	8K	49	5.3	20	1675	115	2795	193	3150	217	—	—	—	—	—	—
	8J	70	7.5	28	755	52	1515	104	2700	186	3150	217	—	—	—	—
	8H	95	10.2	38	510	35	1170	81	2100	145	2885	199	3150	217	—	—
	8G	113	12.2	46	340	23	910	63	1755	121	2390	165	3150	217	—	—
	8F	142	15.3	57	240	17	700	48	1445	100	1930	133	2895	200	3150	217
1" (25 mm)	8K	49	14	53	545	38	875	60	1250	86	—	—	—	—	—	—
	8J	70	19	72	305	21	575	40	860	59	1250	86	—	—	—	—
	8H	95	26	98	205	14	420	29	635	44	955	66	1250	86	—	—
	8G	113	31	117	160	11	355	24	535	37	850	59	1250	86	—	—
	8F	142	39	148	120	8	285	20	425	29	755	52	1130	78	1250	86
1 1/4" (32 mm)	8K	49	21	79	345	24	555	38	770	53	—	—	—	—	—	—
	8J	70	30	114	195	13	365	25	550	38	770	53	—	—	—	—
	8H	95	40	151	130	9	270	19	405	28	610	42	770	53	—	—
	8G	113	48	182	100	7	225	16	340	23	545	38	770	53	—	—
	8F	142	61	231	75	5	180	12	270	19	480	33	720	50	770	53
1 1/2" (38 mm)	8K	49	34	129	220	15	350	24	500	34	—	—	—	—	—	—
	8J	70	48	182	120	8	230	16	345	24	500	34	—	—	—	—
	8H	95	65	246	80	6	170	12	255	18	385	27	500	34	—	—
	8G	113	77	291	60	4	140	10	215	15	340	23	500	34	—	—
	8F	142	97	367	45	3	110	8	170	12	300	21	455	31	500	34
2" (51 mm)	8K	49	52	197	140	10	225	16	300	21	—	—	—	—	—	—
	8J	70	75	284	75	5	145	10	220	15	300	21	—	—	—	—
	8H	95	101	382	50	3	105	7	160	11	245	17	300	21	—	—
	8G	113	120	454	—	—	90	6	135	9	220	15	300	21	—	—
	8F	142	151	572	—	—	70	5	105	7	190	13	300	21	—	—
2 1/2" (64 mm)	8K	49	83	314	85	6	140	10	165	11	—	—	—	—	—	—
	8J	70	119	450	50	3	90	6	140	10	165	11	—	—	—	—
	8H	95	161	609	—	—	65	4	100	7	155	11	165	11	—	—
	8G	113	191	723	—	—	55	4	85	6	135	9	165	11	—	—
	8F	142	240	908	—	—	—	—	65	4	120	8	165	11	—	—
3 1/2" (89 mm)	8K	49	170	643	—	—	70	5	100	7	—	—	—	—	—	—
	8J	70	242	916	—	—	—	—	65	4	100	7	—	—	—	—
	8H	95	330	1249	—	—	—	—	50	3	75	5	100	7	—	—
	8G	113	391	1480	—	—	—	—	—	—	65	4	100	7	—	—
	8F	142	500	1892	—	—	—	—	—	—	60	4	90	6	100	7
4" (102 mm)	8K	49	216	820	—	—	50	3	75	5	—	—	—	—	—	—
	8J	70	308	1165	—	—	—	—	50	3	75	5	—	—	—	—
	8H	95	419	1585	—	—	—	—	—	—	60	4	75	5	—	—
	8G	113	498	1885	—	—	—	—	—	—	50	3	75	5	—	—
	8F	142	626	2370	—	—	—	—	—	—	45	3	70	5	75	5

Capacities listed are for discharge pressures up to 200 PSIG (14 Bar). Capacity will decrease 0.8% for each 100 PSIG (7 Bar) over 200 PSIG (14 Bar).

NOTES:

- * For single phase motors, increase horsepower by one size — example: increase 1/2 hp (0.37kW) to 3/4 hp (0.55kW).
- † Plastic liquid ends are limited to 150 PSIG (10 Bar) @ 68°F (20°C) and are linearly derated to 65 PSIG (4 Bar) @ 140°F (60°C).
- ‡ Derate capacity by 5% when applying a diaphragm rupture detection system.



HIGH PERFORMANCE DIAPHRAGM (HPD) LIQUID END DIMENSIONS*

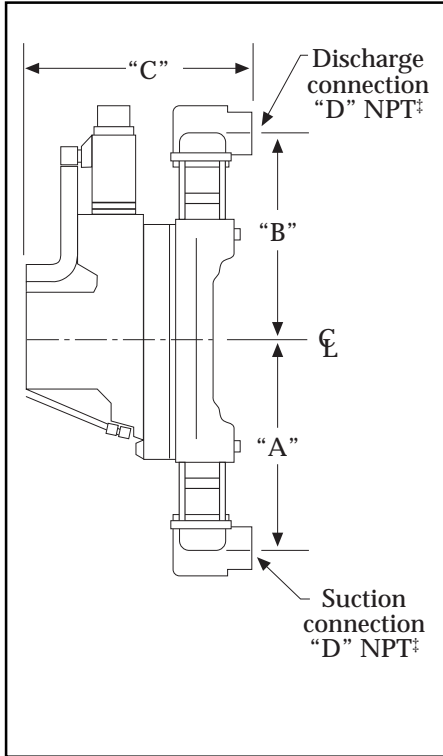

Material	Plunger Diameter		A*		B*		C		D
	in.	mm	in.	mm	in.	mm	in.	mm	in.
Metal	7/16"	11	4 ²⁵ /32"	121	4 ²⁵ /32"	121	4"	102	1/2"
	9/16"	14	4 ²⁵ /32"	121	4 ²⁵ /32"	121	4"	102	1/2"
	5/8"	16	4 ²⁵ /32"	121	4 ²⁵ /32"	121	4"	102	1/2"
	1"	25	4 ¹³ /16"	122	4 ¹³ /16"	122	6 ¹ /8"	156	1/2"
	1 ¹ /4"	32	5 ⁷ /32"	133	5 ⁷ /32"	133	6 ¹ /8"	156	1/2"
	1 ¹ /2"	38	7 ¹ /16"	179	7 ¹ /16"	179	8 ¹ /4"	210	1"
	2"	51	7 ⁹ /16"	192	7 ⁹ /16"	192	8 ¹ /4"	210	1"
	2 ¹ /2"	64	7 ⁹ /16"	192	7 ⁹ /16"	192	8 ¹ /4"	210	1"
	3 ¹ /2"	89	10 ¹ /8"	257	10 ¹ /8"	257	13"	330	1 ¹ /2"
	4"	102	10 ¹ /2"	257	10 ¹ /8"	257	13"	330	1 ¹ /2"
Plastic	1"	25	6 ¹ /2"	165	6 ¹ /2"	165	6 ¹⁵ /16"	176	1/2"
	1 ¹ /4"	32	6 ¹ /2"	165	6 ¹ /2"	165	6 ¹⁵ /16"	176	1/2"
	1 ¹ /2"	38	9 ⁹ /16"	243	9 ⁹ /16"	243	8 ³ /4"	222	1"
	2"	51	9 ⁹ /16"	243	9 ⁹ /16"	243	8 ³ /4"	222	1"
	2 ¹ /2"	64	9 ⁹ /16"	243	9 ⁹ /16"	243	8 ³ /4"	222	1"
	3 ¹ /2"	89	16" [‡]	406 [‡]	13"	330	13 ¹ /4" [‡]	337 [‡]	1 ¹ /2"
	4"	102	16" [‡]	406 [‡]	13"	330	13 ¹ /4" [‡]	337 [‡]	1 ¹ /2"

NOTES:

* Dimensions shown are for single diaphragm liquid ends. Contact factory for double diaphragm dimensions.

† A & B dimensions are based on standard ball check configuration: Metallic = single ball checks, Plastic = double ball checks. Consult factory for dimensions on optional configurations.

‡ Suction and discharge connections are horizontal in metal and vertical in plastic except on plastic 3-1/2" (89 mm) plunger, where suction is horizontal, discharge is vertical and dimension "C" for discharge is 10-13/16" (275 mm).

MAXIMUM ALLOWABLE SUCTION PRESSURE RANGE — HPD

Plunger Diameter		Standard		Mid Range		High Range	
in.	mm	PSIG	Bar	PSIG	Bar	PSIG	Bar
7/16"	11	660	46	1130	77	1450	98
9/16"	14	460	31	770	53	985	68
5/8"	16	360	25	590	40	750	51
1"	25	100	7	—	—	—	—
1 ¹ /4"	32	100	7	—	—	—	—
1 ¹ /2"	38	85	6	100	7	—	—
2"	51	60	4	85	6	100	7
2 ¹ /2"	64	45	3	60	4	70	5
3 ¹ /2"	89	20	1.3	35	2	40	3
4"	100	15	1	25	1.5	30	2

MILROYAL B



HIGH PERFORMANCE DIAPHRAGM (HPD) LIQUID END MODEL CODE

MILROYAL B

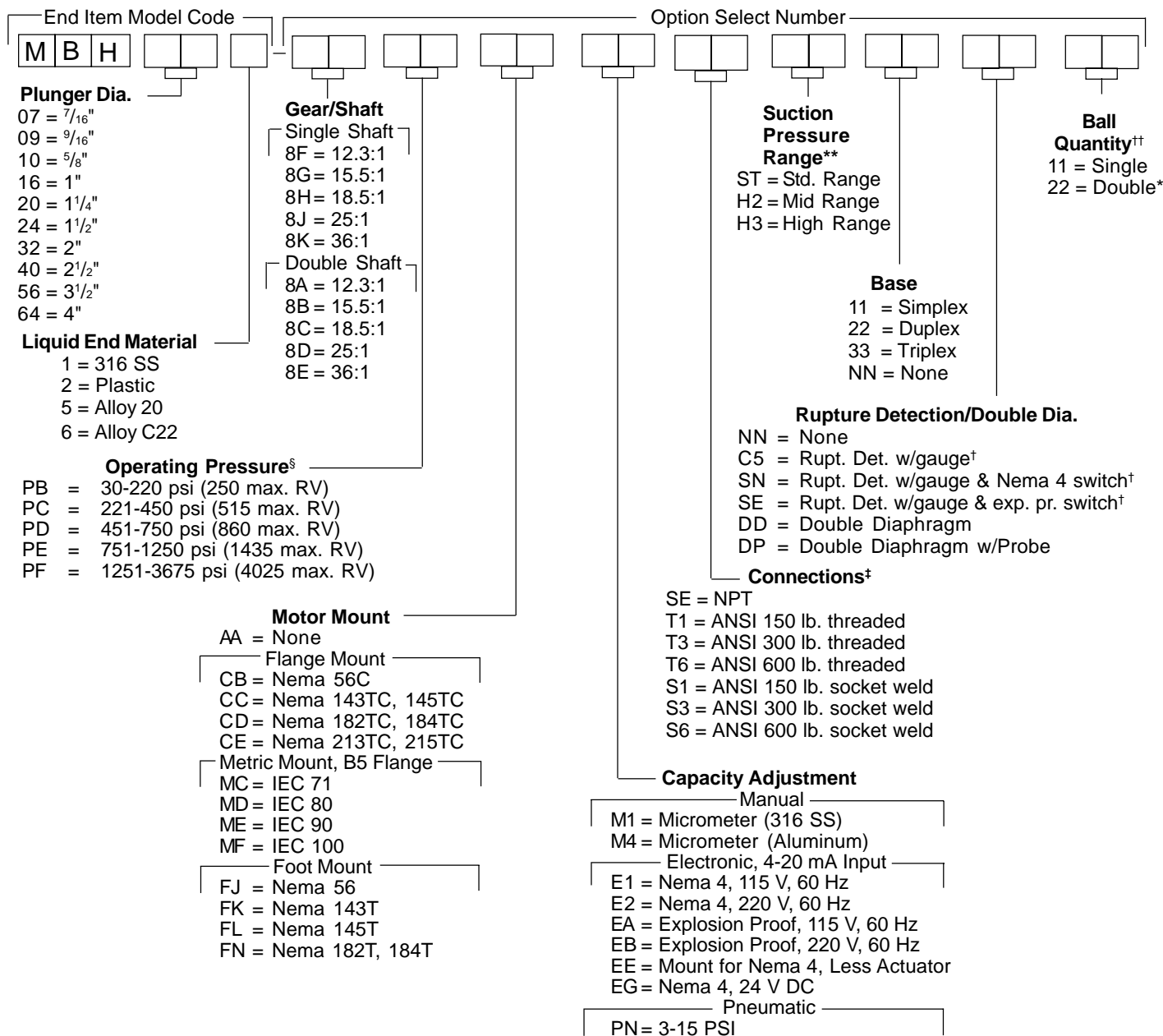

NOTES:

- [§] Operating pressure is the pressure of the applications system. The internal relief valve is normally set 15% above the operating pressure. If an internal relief valve setting greater than 15% above the operating pressure range is required, select the operating pressure that will accommodate the relief valve setting.
- [‡] Flange sizes equal the NPT connection size as noted on the liquid end drawing.
- ** Refer to the suction pressure table for maximum suction pressure vs. range.
- [†] Options C5, SN, and SE are only available on metallic liquid ends.
- ^{††} Special ball check and seat materials are available for severe slurry service. Contact factory.
- * Plastic liquid ends are only available with double ball checks.



DISC DIAPHRAGM LIQUID END PERFORMANCE

Typical performance based on 1725 RPM, 3 phase, 60 hz motor. Derate flow rates for all other RPM speeds.*

Plunger Dia.	Gear Ratio Code	SPM @ 1725 RPM	Maximum Capacity*		Maximum Discharge Pressure†											
					1/3 HP (0.25 kw)		1/2 HP (0.37 kw)		3/4 HP (0.55 kw)		1 HP (0.75 kw)		1 1/2 HP (1.1 kw)		2 HP (1.5 kw)	
					GPH	L/H	PSIG	BAR	PSIG	BAR	PSIG	BAR	PSIG	BAR	PSIG	BAR
7/16" (11 mm)	8K	49	2.1	7	3440	237	3500	241	—	—	—	—	—	—	—	—
	8J	70	3.0	11	1625	112	3215	222	3500	241	—	—	—	—	—	—
	8H	95	4.0	15	1110	77	2440	168	3500	241	—	—	—	—	—	—
	8G	113	4.9	18	775	53	1905	131	3500	241	—	—	—	—	—	—
	8F	142	6.1	23	575	40	1475	102	2950	203	3500	241	—	—	—	—
5/8" (16 mm)	8K	49	5.3	20	1675	115	2795	193	3150	217	—	—	—	—	—	—
	8J	70	7.5	28	755	52	1515	104	2700	186	3150	217	—	—	—	—
	8H	95	10.2	38	510	35	1170	81	2100	145	2885	199	3150	217	—	—
	8G	113	12.2	46	340	23	910	63	1755	121	2390	165	3150	217	—	—
	8F	142	15.3	57	240	17	700	48	1445	100	1930	133	2895	200	3150	217
7/8" (22 mm)	8K	49	9.6	36	800	55	1385	95	1500	103	—	—	—	—	—	—
	8J	70	13.8	52	350	24	750	52	1320	91	1500	103	—	—	—	—
	8H	95	18.6	70	225	16	560	39	1025	71	1500	103	—	—	—	—
	8G	113	22.0	83	140	10	425	29	850	59	1205	83	1500	103	—	—
	8F	142	27.6	104	90	6	345	24	740	51	985	68	1500	103	—	—
1 1/8" (28 mm)	8K	49	16.2	61	460	32	810	56	900	62	—	—	—	—	—	—
	8J	70	23.0	87	185	13	430	30	770	53	900	62	—	—	—	—
	8H	95	31.4	118	115	8	310	21	590	41	900	62	—	—	—	—
	8G	113	37.0	140	65	4	230	16	485	33	720	50	900	62	—	—
	8F	142	47.5	179	35	2	185	13	420	29	595	41	900	62	—	—
1 1/2" (38 mm)	8K	49	28.5	107	240	17	435	30	500	34	—	—	—	—	—	—
	8J	70	41.0	155	90	6	225	16	420	29	500	34	—	—	—	—
	8H	95	56.0	212	45	3	160	11	315	22	500	34	—	—	—	—
	8G	113	67.0	253	—	—	115	8	255	18	400	28	500	34	—	—
	8F	142	84.0	317	—	—	90	6	225	16	335	23	500	34	—	—
1 3/4" (44 mm)	8K	49	39.0	147	175	12	320	22	360	25	—	—	—	—	—	—
	8J	70	55.8	211	55	4	155	11	295	20	360	25	—	—	—	—
	8H	95	76	287	—	—	110	8	225	16	360	25	—	—	—	—
	8G	113	91	344	—	—	75	5	180	12	270	19	360	25	—	—
	8F	142	114	431	—	—	60	4	155	11	220	15	360	25	—	—
2 1/2" (64 mm)	8K	49	83	314	70	5	145	10	165	11	—	—	—	—	—	—
	8J	70	119	451	—	—	60	4	135	9	165	11	—	—	—	—
	8H	95	161	609	—	—	40	3	95	7	165	11	—	—	—	—
	8G	113	190	719	—	—	—	—	70	5	125	9	165	11	—	—
	8F	142	240	908	—	—	—	—	65	4	95	7	165	11	—	—

Capacities listed are for discharge pressures up to 1000 PSIG (69 Bar).
 Derate capacities above by 1.0% for each 100 PSIG (7 Bar) over 1000 PSIG (69 Bar).

NOTES:

- * For single phase motors, increase horsepower by one size — example: increase 1/2 hp (0.37 kW) to 3/4 hp (0.55 kW).
- † Plastic liquid ends are limited to 150 PSIG (10 Bar) @ 68°F (20°C) and are linearly derated to 65 PSIG (4 Bar) @ 140°F (60°C).

MILROYAL B



MILROYAL B

DISC DIAPHRAGM LIQUID END DIMENSIONS *

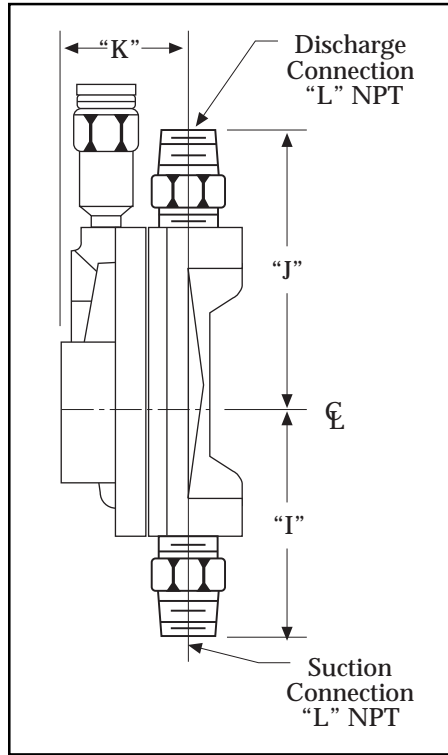

Material	Plunger Diameter		I		J		K		L
	in.	mm	in.	mm	in.	mm	in.	mm	in.
Metal	7/16"	11	4 3/4"	121	5 1/2"	140	3"	76	1/2"
	5/8"	16	4 3/4"	121	5 1/2"	140	3"	76	1/2"
	7/8"	22	5 3/4"	146	6 7/8"	175	3 7/16"	87	1"
	1 1/8"	28	5 3/4"	146	6 7/8"	175	3 7/16"	87	1"
	1 1/2"	38	6 7/16"	164	7 15/16"	202	3 5/8"	92	1 1/4"
	1 3/4"	44	6 7/16"	164	7 15/16"	202	3 5/8"	92	1 1/4"
Plastic	2 1/2"	64	6 15/16"	176	10 5/16"	265	3 7/8"	98	1 1/2"
	7/16"	11	4 11/16"	119	5 7/16"	138	3 3/16"	81	1/2"
	5/8"	16	4 11/16"	119	5 7/16"	138	3 3/16"	81	1/2"
	7/8"	22	5 1/4"	133	6 3/8"	162	3 1/2"	89	1"
	1 1/8"	28	5 1/4"	133	6 3/8"	162	3 1/2"	89	1"
	1 1/2"	38	6 15/16"	176	8 7/16"	214	3 7/8"	98	1 1/4"
1 3/4"	44	6 15/16"	176	8 7/16"	214	3 7/8"	98	1 1/4"	
2 1/2"	64	7 7/16"	189	10 15/16"	278	4 1/16"	103	1 1/2"	

NOTES:

* Dimensions shown are for single diaphragm liquid ends. Contact factory for double diaphragm dimensions.

MAXIMUM ALLOWABLE SUCTION PRESSURE RANGE — DISC DIAPHRAGM

Plunger Diameter		Maximum Range	
in.	mm	PSIG	Bar
7/16"	11	660	46
5/8"	16	360	25
7/8"	22	208	14
1 1/8"	28	142	10
1 1/2"	38	94	6
1 3/4"	44	75	5
2 1/2"	64	46	3



MILROYAL B DISC DIAPHRAGM LIQUID END MODEL CODE

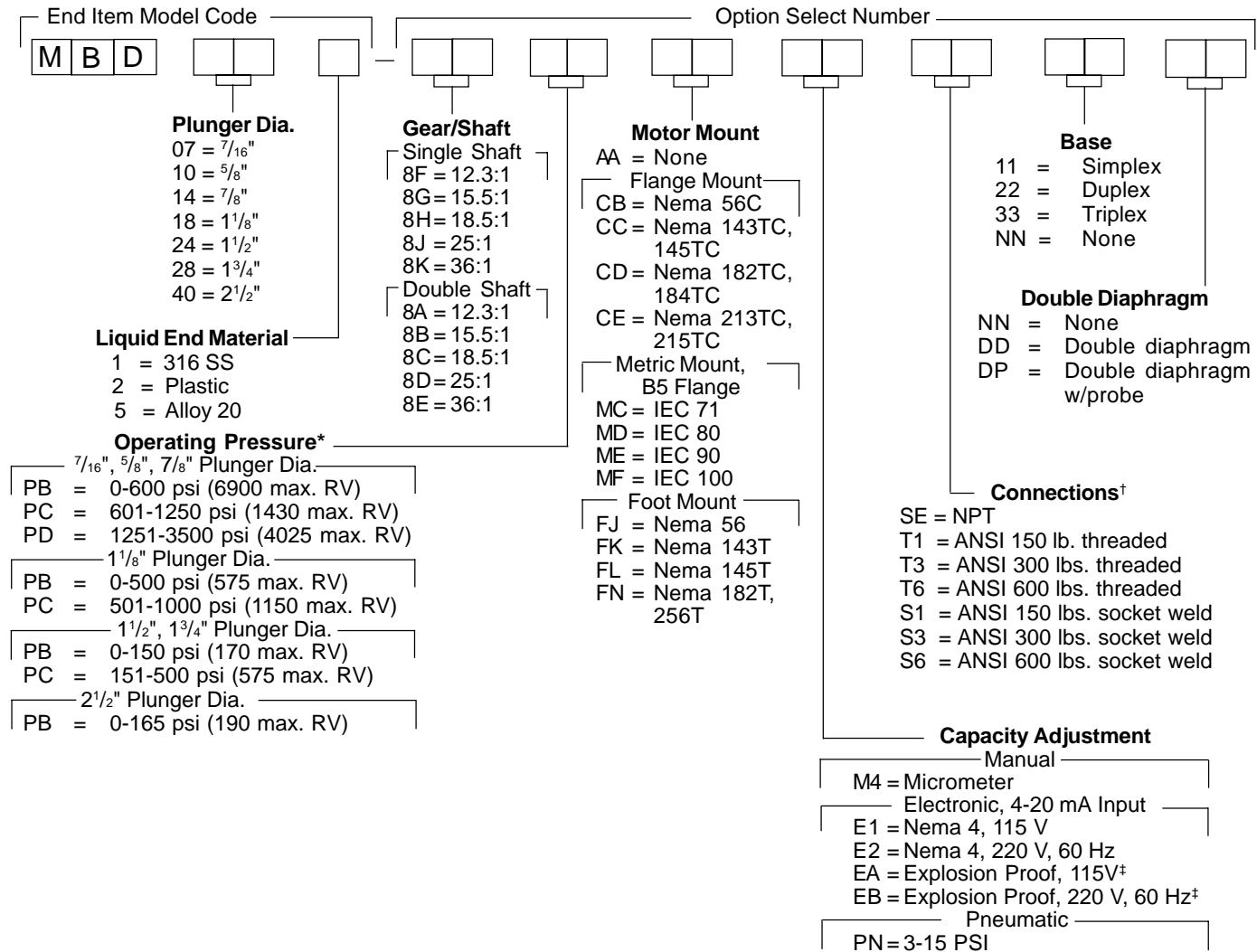

MILROYAL B

NOTES:

* Operating pressure is the pressure of the applications system. The internal relief valve is normally set 15% above the operating pressure. If an internal relief valve setting greater than 15% above the operating pressure range is required, select the operating pressure that will accommodate the relief valve setting.

† Flange sizes equal the NPT connection size as noted on the liquid end drawing.

1. Double ball checks are standard.



MILROYAL B

PACKED PLUNGER LIQUID END PERFORMANCE

Typical performance based on 1725 RPM, 3 phase*, 60 hz motor. Derate flow rates for all other RPM speeds.

Plgr. Dia.	Gear Ratio Code	SPM @ 1725 RPM	Maximum Capacity		1/3 HP (0.25 kw)		1/2 HP (0.37 kw)		3/4 HP (0.55 kw)		1 HP (0.75 kw)		1 1/2 HP (1.1 kw)		2 HP (1.5 kw)	
					PSIG	BAR	PSIG	BAR	PSIG	BAR	PSIG	BAR	PSIG	BAR	PSIG	BAR
			GPH	L/H	Maximum Discharge Pressure*											
5/16" (8 mm)	8K	49	1.1	4	4470	308	7500	517	10000	1450	—	—	—	—	—	—
	8J	70	1.6	6	3130	216	5870	405	7500	517	10000	1450	—	—	—	—
	8H	95	2.2	8	2115	146	4470	308	7500	517	10000	1450	—	—	—	—
	8G	113	2.7	10	1535	106	3635	251	6545	451	7500	517	10000	1450	—	—
	8F	142	3.4	12	1155	80	3085	213	5210	359	6945	479	7500	517	10000	1450
7/16" (11 mm)	8K	49	2.2	8	2280	157	4280	295	6450	445	—	—	—	—	—	—
	8J	70	3.2	12	1595	110	2995	207	4790	330	6450	445	—	—	—	—
	8H	95	4.4	16	1030	71	2280	157	3860	266	5150	355	6450	445	—	—
	8G	113	5.3	20	740	51	1855	128	3245	224	4330	299	6450	445	—	—
	8F	142	6.6	25	525	36	1575	109	2655	183	3545	244	5315	366	6450	445
5/8" (16 mm)	8K	49	5.0	18	1120	77	2095	144	3175	219	—	—	—	—	—	—
	8J	70	7.1	26	755	52	1465	101	2350	162	3175	219	—	—	—	—
	8H	95	9.6	36	480	33	1080	74	1840	127	2450	169	3175	219	—	—
	8G	113	11.5	43	325	22	880	61	1545	107	2060	142	3090	213	3175	219
	8F	142	14.4	54	225	16	745	51	1300	90	1735	120	2605	180	3175	219
7/8" (22 mm)	8K	49	10.1	38	570	39	995	69	1555	107	—	—	—	—	—	—
	8J	70	14.4	54	345	24	720	50	1160	80	1555	107	—	—	—	—
	8H	95	19	74	205	14	530	37	910	63	1210	83	1555	107	—	—
	8G	113	23	87	120	8	415	29	765	53	1020	70	1555	107	—	—
	8F	142	29	109	80	6	340	23	660	45	885	61	1325	91	1555	107
1 1/8" (28 mm)	8K	49	17	64	335	23	580	40	915	63	—	—	—	—	—	—
	8J	70	24	90	190	13	420	29	655	45	915	63	—	—	—	—
	8H	95	33	124	100	7	285	20	530	37	710	49	915	63	—	—
	8G	113	39	147	50	3	220	15	445	31	595	41	915	63	—	—
	8F	142	50	189	—	—	175	12	380	26	505	35	755	52	915	63
1 1/2" (38 mm)	8K	49	30	113	160	11	315	22	505	35	—	—	—	—	—	—
	8J	70	44	166	90	6	220	15	340	23	505	35	—	—	—	—
	8H	95	59	223	—	—	150	10	280	19	375	26	505	35	—	—
	8G	113	70	265	—	—	110	8	235	16	315	22	505	35	—	—
	8F	142	88	333	—	—	80	6	200	14	265	18	400	28	505	35
1 3/4" (44 mm)	8K	49	41	155	110	8	220	15	360	25	—	—	—	—	—	—
	8J	70	59	223	50	3	155	11	250	17	360	25	—	—	—	—
	8H	95	80	302	—	—	90	6	200	14	265	18	360	25	—	—
	8G	113	95	359	—	—	70	5	160	11	215	15	360	25	—	—
	8F	142	120	454	—	—	45	3	125	9	170	12	255	18	360	25
2 1/2" (64 mm)	8K	49	85	323	—	—	100	7	165	11	—	—	—	—	—	—
	8J	70	121	458	—	—	60	4	105	7	165	11	—	—	—	—
	8H	95	164	620	—	—	—	—	80	6	105	7	165	11	—	—
	8G	113	195	738	—	—	—	—	55	4	75	5	135	9	165	11
	8F	142	245	927	—	—	—	—	50	3	65	4	105	7	165	11

Capacities listed are for discharge pressures up to 2000 PSIG (137 Bar).
Derate capacities by 6% for each 1000 PSIG (68 Bar) over 2000 PSIG (137 Bar).

NOTE:

* For single phase motors, increase horsepower by one size — example: increase 1/2 hp (0.37 kW) to 3/4 hp (0.55 kw).



PACKED PLUNGER LIQUID END DIMENSIONS

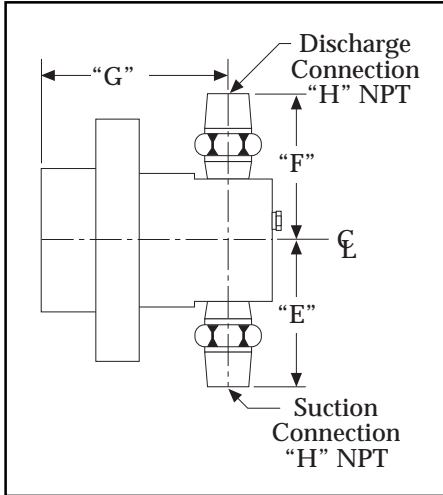

Pressure	Plunger Diameter		E		F		G		H
	in.	mm	in.	mm	in.	mm	in.	mm	in.
0-4999 PSIG (0-344 BAR)	5/16"	08	3"	76	3"	76	4"	108	1/2"
	7/16"	11	3"	76	3"	76	6 1/8"	108	1/2"
	5/8"	16	3"	76	3"	76	6 1/8"	108	1/2"
	7/8"	22	3 1/2"	89	3 1/2"	89	8 1/4"	108	1"
	1 1/8"	28	3 9/16"	90	3 9/16"	90	8 1/4"	102	1"
	1 1/2"	38	4 7/16"	113	4 7/16"	113	8 1/4"	102	1 1/4"
5000+ PSIG (345+ BAR)	1 3/4"	44	4 7/16"	113	4 7/16"	113	13"	102	1 1/4"
	2 1/2"	64	7 3/8"	187	7 3/8"	187	13"	184	2 1/2"
	5/16"	08	3 5/16"	84	3 5/16"	84	4 1/2"	114	3/4"
	7/16"	11	3 5/16"	84	3 5/16"	84	4 1/2"	114	3/4"

MILROYAL B

MAXIMUM ALLOWABLE SUCTION PRESSURE RANGE — PACKED PLUNGER

Plunger Diameter		Standard		Mid Range		High Range	
in.	mm	PSIG	Bar	PSIG	Bar	PSIG	Bar
5/16"	08	1180	81	2120	146	2750	190
7/16"	11	660	46	1130	78	1450	100
5/8"	16	360	25	590	41	750	52
7/8"	22	208	14	330	23	410	28
1 1/8"	28	142	10	215	15	265	18
1 1/2"	38	94	6	135	9	165	11
1 3/4"	44	75	5	104	7	125	9
2 1/2"	64	46	3	60	4	70	5



PACKED PLUNGER LIQUID END MODEL CODE

MILROYAL B

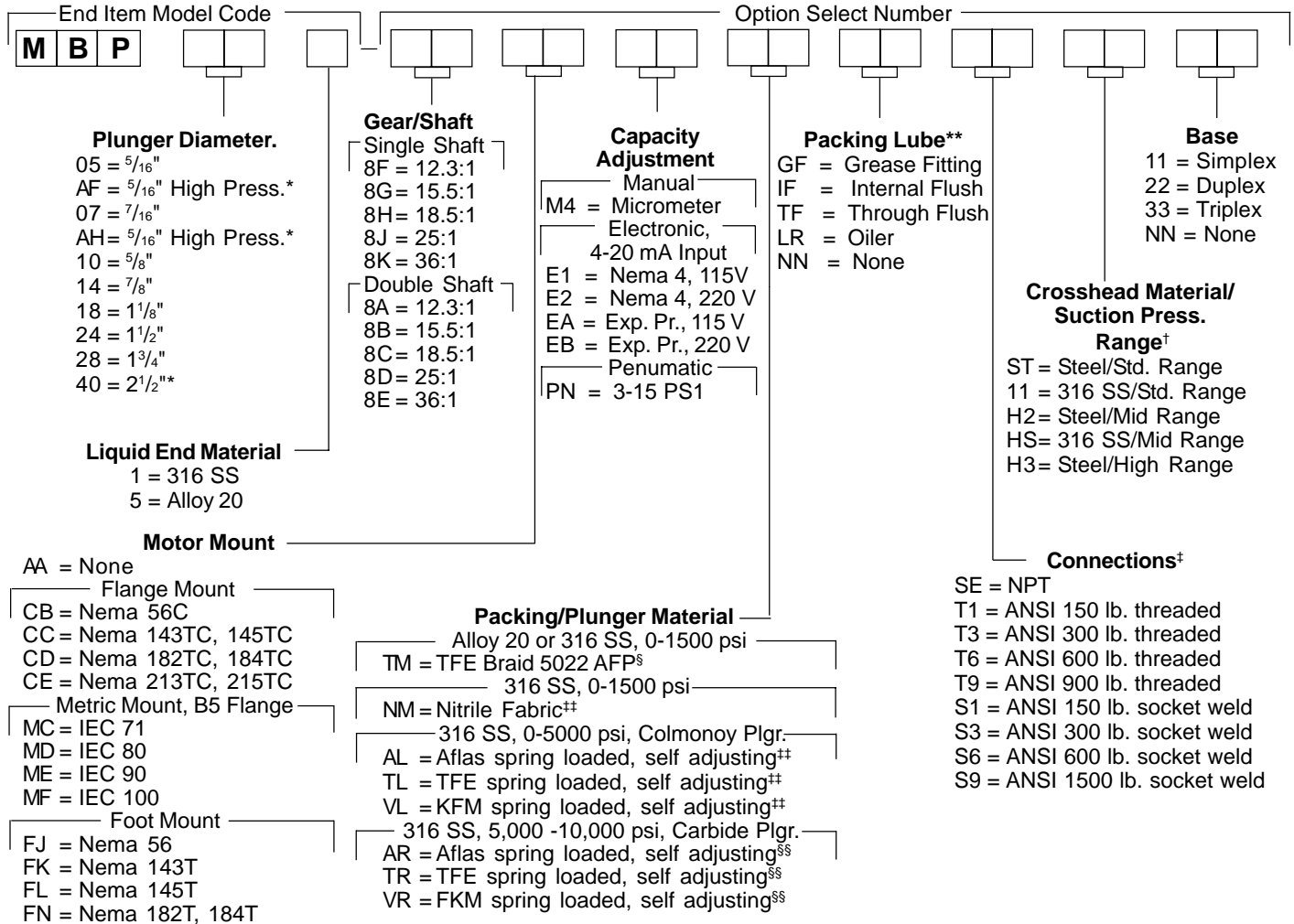

NOTES:

- * Plunger Diameter Codes AF and AH are available in 316 SS only and are for applications requiring pressures over 5000 psi.
- † Refer to suction pressure table for suction pressure vs. range.
- ‡ Flange sizes equal the NPT connection size as noted on the liquid end drawing.
- § The plunger material will automatically match the liquid end material when selecting packing/plunger material code TM.
- ** Select packing lube GF with packing codes TM & NM. Contact Applications Engineering for other packing lube selection.
- †† Packing code NM is a standard option for 316 SS liquid ends with plunger diameters of 1-1/8" through 2-1/2" plungers.
- ‡‡ Packing/plunger codes AL, TL, & VL are offered on 316 SS liquid ends with 5/16" through 7/8" plunger diameters.
- §§ Packing/plunger codes AR, TR, & VR are offered on 316 SS liquid ends with 5/16" or 7/16" high pressure plunger diameters.



HPD LIQUID END MATERIALS OF CONSTRUCTION—WETTED PARTS

Materials of Construction	Diaphragm	Diaphragm Head	Port Connection	Ball Seat	Ball Check	Ball Guide
316 SS*	PTFE/Elastomer	316 SS CF-8M‡	316 SS CF-8M‡	316 SS	316 SS	316 SS CF-8M‡
Alloy 20*	PTFE/Elastomer	20CB-3 CN-7M	20CB-3 CN-7M	20CB-3	20CB-3	20CB-3 CN-7M
Plastic*	PTFE/Elastomer	PVC	PVC	PVC	Ceramic	PVC
Alloy C22*	PTFE/Elastomer	Alloy C22 CX2MW†	Alloy C22 CX2MW†	Alloy C22	Alloy C22	Alloy C22 CX2MW†

NOTES:

* Temperature range for metallic versions is 10°F (-12°C) to 190°F (88°C) standard, optional to 225°F (107°C), special to 300°F (149°C). Temperature range for plastic versions is 10°F (-12°C) to 140°F (60°C).

‡ CF-8M is the cast equivalent to wrought 316 SS.

§ CN-7M is the cast equivalent to wrought 20CB-3.

† CX2MW is the cast equivalent to wrought Alloy C22.

DISC DIAPHRAGM MATERIALS OF CONSTRUCTION—WETTED PARTS

Materials of Construction	Diaphragm Head	Cartridge Body	Seats	Balls	Limit Pins	Diaphragm	Contour Plate
316 SS†	316 SS CF-8M‡	316 SS CF-8M‡	316 SS	316 SS	316 SS	PTFE	316 SS CF-8M‡
Alloy 20†	20CB-3 CN-7M	20CB-3 CN-7M	20CB-3	20CB-3	20CB-3	PTFE	20CB-3 CN-7M
Plastic	Acrylic Plastic*	PVC	PVC	Ceramic	Alloy C	PTFE	(none)

NOTES:

* Diaphragm head is polypropylene on plastic 2-1/2".

† Maximum temperature for metallic liquid ends is 250°F (121°C). Maximum temperature for plastic liquid ends is 140°F (60°C).

‡ CF-8M is the cast equivalent to wrought 316 SS.

§ CN-7M is the cast equivalent to wrought 20CB-3.

PACKED PLUNGER MATERIALS OF CONSTRUCTION—WETTED PARTS

Liquid End Material	Plunger	Check Valve	Seat	Seat Seal	Ball	Lantern Ring/ Spacers	Packing Spring	Gland Cap
316 SS	316 SS (to 1500 psi)	316 SS CF-8M*	316 SS	PTFE	316 SS	316 SS CF-8M*	N/A	316 SS CF-8M*
	Colmonoy (to 5000 psi)	316 SS CF-8M*	316 SS	PTFE	316 SS	316 SS CF-8M*	316 SS	316 SS CF-8M*
	Carbide (to 10,000 psi)	316 SS CF-8M*	Hardened 13-8 Mo	PTFE	Carbide	316 SS CF-8M*	316 SS	316 SS CF-8M*
Alloy 20	20CB-3 (to 1500 psi)	20CB-3 CN-7M†	20CB-3	PTFE	20CB-3	20CB-3 CN-7M†	N/A	20CB-3 CN-7M†

NOTES:

* CF-8M is the cast equivalent to wrought 316 SS.

† CN-7M is the cast equivalent to wrought 20CB-3.



DRIVE DIMENSIONS

MILROYAL B

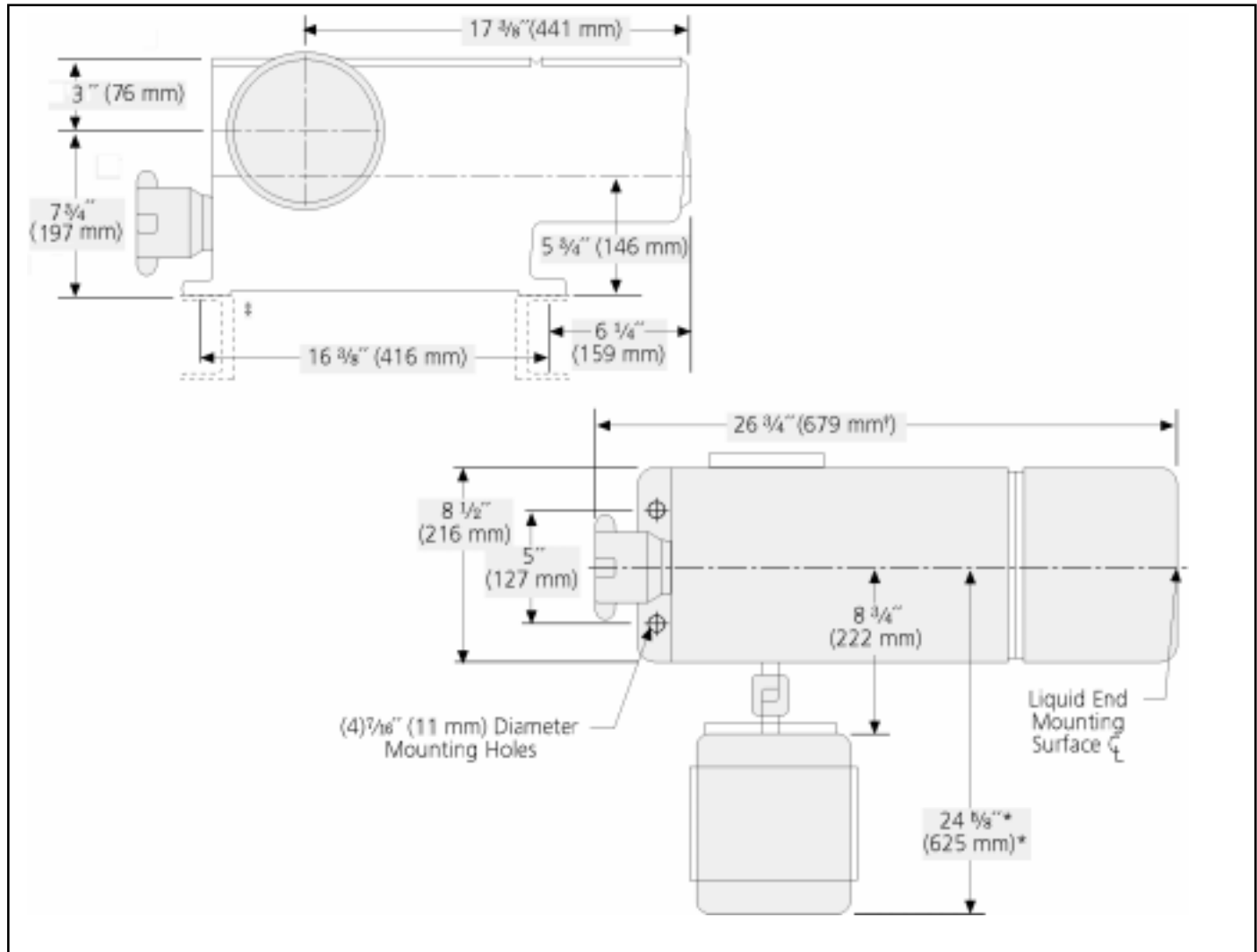

NOTES:

* Dimension shown is for the largest available motor.

† Various bases are supplied with certain liquid ends and multiplex units. Consult factory for exact mounting dimensions.

‡ 26 3/4" (679 mm) is the dimension for manual stroke adjustment. For electronic stroke, overall length is 41 5/8" (1311 mm).

AVAILABLE OPTIONS

- Double diaphragm
- Diaphragm rupture detection system
- Flanged connections
- Electronic capacity control
- Pneumatic capacity control
- Severe duty motors
- Variable speed drives
- Custom options available to fit your application

ACCESSORIES

- Safety valves
- Back pressure valves
- Calibration columns
- Pulsation dampeners
- Tanks & standard systems
- Sludge traps

All information contained herein subject to change without notice.

